

Assembly and adjustment instructions for fine-boring tools with expansion articulation

Original version of the instructions
Version: 01/2017



The document was prepared by Gühring KG.

All rights on this documentation, in particular the right of copying, distributing and translating the document remain with Gühring KG, also for the case of the registration of patent rights. No part of this document may be reproduced or be processed, copied or distributed with electronic media without prior written approval from Gühring KG.



CONTENTS

1	Information About these Instructions	3
1.1	Read the Operating Instructions	3
1.2	Explanation of the General Icons	3
1.3.1	Structure of Warnings	4
1.3.2	Employed Safety Notes	4
1.4	Representation of Requirements and Work Instructions	4
1.4.1	Requirements	4
1.4.2	Work Instructions with Fixed Sequence	5
2	Identification of the Tool	5
2.1	Tool Identification	5
2.2	Manufacturer Specifications	5
3	Tool Description, Specifications	5
3.1	Intended Use	5
3.2	Improper Use	6
3.3	Specifications	6
4	Basic Safety Instructions	6
5	Installing and Adjusting the Tool	6
5.1	Initial Safety Notes	6
5.2	General Information	7
5.3	Designation of the Individual Parts	7
5.4	Method of Operation of the Expansion Articulation	8
5.5	Fine Adjustment of the Expansion Articulation	9
5.6	New Adjustment of the Expansion Articulation	10
5.7	Torque Values	13



1 Information About these Instructions

1.1 Read the Operating Instructions

Use and handling of the tool described below are not natural or self-explaining. They are therefore explained by the accompanying technical documentation.

The instructions help you to use the tool as intended, properly, effectively and safely. You should therefore read the chapters below attentively and thoroughly. If necessary, look up the decisive facts whenever you need it.

Request new operating instructions if parts of them are lost or damaged. Always keep the operating instructions at an accessible place in the vicinity of the tool.



Important information in the enclosed "General Safety Instructions" document



The safety instructions that are necessary for handling the tool can be found in the brief version of the "General Safety Instructions" that are enclosed with the tool.

Ensure that you read and observe this document.

Residual risks

The documents inform and warn you of residual risks for which the risk reduction by design and protective measures takes no or no complete effect.

1.2 Explanation of the General Icons

Icon	Explanation
	Important information This icon shows important additional information.
	Information about the machine documentation This icon refers to other parts of the documentation that must particularly or additionally be observed (for example in supplier instructions, etc.).
	Information about possible damage This icon shows that there is the possibility of material damage.

Tab. 1: General icons



1.3.1 Structure of Warnings

The warnings in this document are highlighted with icons and signal words. Icon and signal word show you the severity of the danger.

The warnings that precede each action are shown as follows:

DANGER (1)	
	Type and source of the danger (2) Explanation of type and source of the danger. (3) ➤ Measures to avert the danger. (4)

The warnings are of the following structure:

Position	Information	Contents	Example
1	Danger level	Severity and classification of the danger with signal word and icon	Danger
2	Type and source of the danger	What type of danger exists, and where does it come from?	Danger from electrical current
3	Possible consequences of the danger	What will or can happen when the warning is not observed?	There can be dangerous current flowing through the body when you get into contact with energized parts.
4	Measures to avert or avoid the danger	What can be done? What should not be done? Which protective measures are to be taken?	Have work on electrical systems or equipment only carried out by skilled electricians.

Tab. 2: Structure of warnings

1.3.2 Employed Safety Notes

The following safety notes are used in this document:

NOTE	
	Highlights a potentially harmful situation Not avoiding this situation can cause damage to the system or to something in the system environment.



1.4 Representation of Requirements and Work Instructions

1.4.1 Requirements

Requirements that are obligatory for the execution of an activity on the tool have a checkbox next to them in the text.

Typical requirement

...

The thread is coated with mounting lubricant

1.4.2 Work Instructions with Fixed Sequence

Many activities on the tool require the steps to be taken in a fixed sequence.

These steps have work instructions with consecutive numbering assigned. Work instructions also contain intermediate results and final results. Intermediate results show sequences that are not carried out by the user. They are identified by an arrowhead ▶. End results show the end of the action. They are identified by a tick ✓.

The sequence of the work operations is compulsory. Observing the work instructions is obligatory.

Typical work instructions with fixed sequence

1. Switch on the machine at the main switch
 - ▶ The machine controller starts up
2. Start the software
 - ▶ The software starts and the following menu appears:
 - ✓ Machine and software are ready for operation

2 Identification of the Tool

2.1 Tool Identification

Tool designation: Expansion articulation for fine-boring tools

Part number / SAP no.: See Chapter 3.3 Specifications

Year of manufacture: 2017

2.2 Manufacturer Specifications

Headquarters:

Gühring KG
Herderstr. 50-54
72458 Albstadt
Germany

Phone +49 7431 17-0
Fax +49 7431 17-21279
E-mail info@guehring.de
Internet www.guehring.de



3 Tool Description, Specifications

3.1 Intended Use

Tools with expansion articulation are intended to be used in CNC-controlled machines or machining centres. Use the tool only on machines that are in a proper technical state. Since only optical measurement is allowed for tools with PCD tips, you must ensure that an optical measuring / adjusting unit is available. Tools with expansion articulation are only suitable for fine machining (cutting depth < 1.5 mm).

3.2 Improper Use

Tools with expansion articulation are not intended to be used in manually operated machine tools. Tools with PCD tips must not be measured mechanically. Tools with expansion articulation are not suitable for machining with a cutting depth > 1.5 mm.

3.3 Specifications

Adjusting spindle (countersunk-head screw and adjusting screw)

	Size 1	Size 2	Size 3	Size 4
Ø range	18 ... < 30	30 ... < 38	38 ... < 50	≥ 50
Material no.	400107368	400107369	400107370	400107371
Adjusting screw thread	M4	M5	M6	M8
Adjusting screw length	6	7	9	13
Adjusting screw spanner size	2	2.5	3	4
Countersunk-head screw thread	M2.5	M3	M4	M5
Countersunk-head screw length	8	10	12	16
Countersunk-head screw spanner size	1.5	2	2.5	3
Overall length	11.5	15.4	19.4	26

Tab. 2: Specifications

Emission values

Important information

While the tool does not cause any emission, the machine in which the tool is used does. Always observe the operating instructions of the machine!



4 Basic Safety Instructions

Important information in the document "General Safety Instructions"

The safety instructions necessary for handling the tool can be found in the document "General Safety Instructions". Use the QR code or the link in the brief instructions that are enclosed with the tool to invoke and download the general Safety Instructions.

If you do not have internet access or want the General Safety Instructions in paper form, please contact your contact person at Gühring KG. Gühring KG will send you a hard copy of the document. Please ensure that you read the document "General Safety Instructions" and its brief version.





5 Installing and Adjusting the Tool

5.1 Initial Safety Notes



Important information for your safety

You are responsible!

Always take note and observe the safety instructions in the document "General Safety Instructions" and the locally valid safety instructions.

5.2 General Information

The following information is important for the general handling of the expansion articulation in fine-boring tools:

- If no other specifications exist, all tools with expansion articulation are preadjusted when they are delivered
- Correcting this adjustment may be necessary after the first use in the machine (see Chapter 5.5)
- The countersunk-head screws are properly tightened and sealed

5.3 Designation of the Individual Parts

To have a clear definition of the individual parts, we use the following exploded views to designate them:

Front view of the tool:

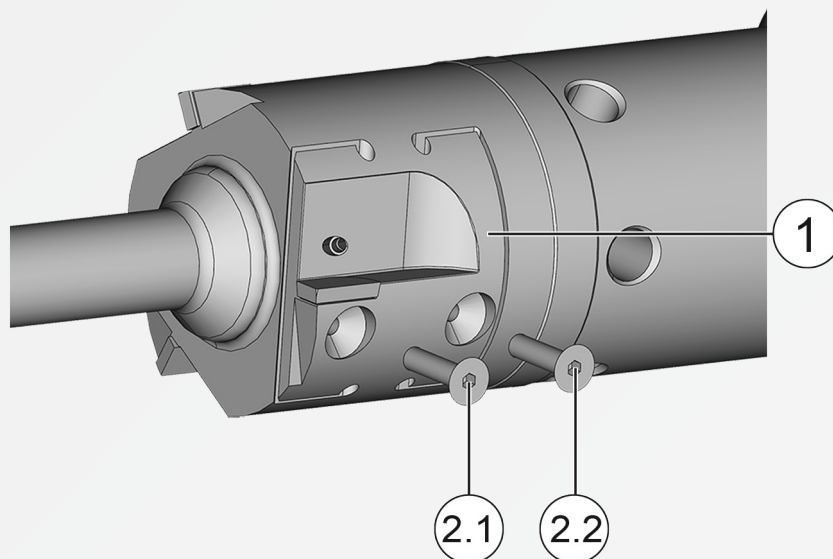

1	Expansion articulation	2.1 / 2.2	Countersunk-head screw
---	------------------------	-----------	------------------------



Rear view of the tool:

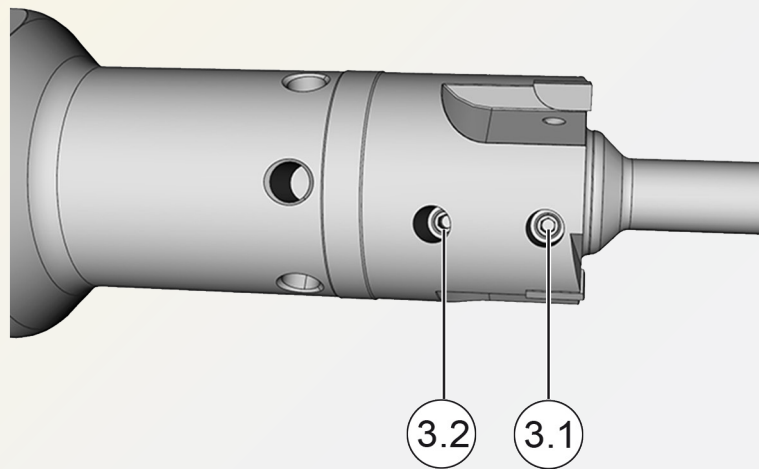

3.1 / 3.2	Adjusting screw with inside and outside thread
-----------	--

Tool cross-section

Adjusting screws and countersunk-head screw together are referred to as adjusting spindle.

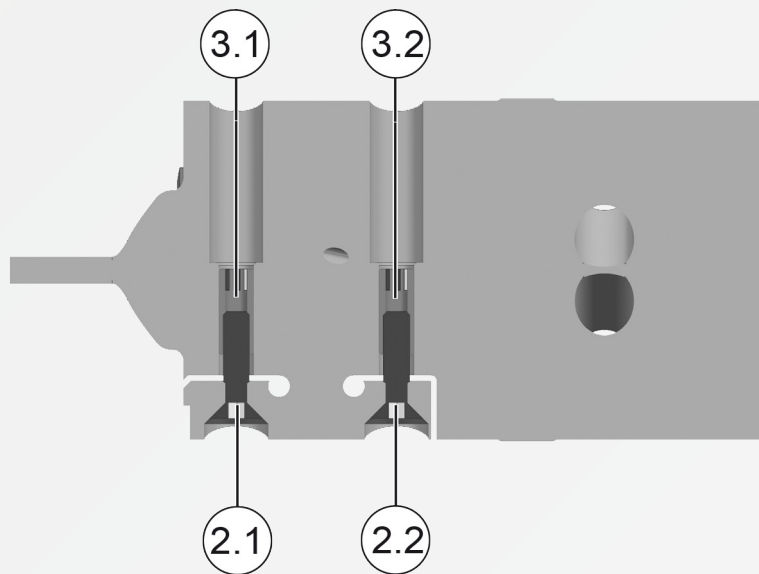

2.1 / 2.2	Countersunk-head screw	3.1 / 3.2	Adjusting screw with inside and outside thread
-----------	------------------------	-----------	--



5.4 Method of Operation of the Expansion Articulation

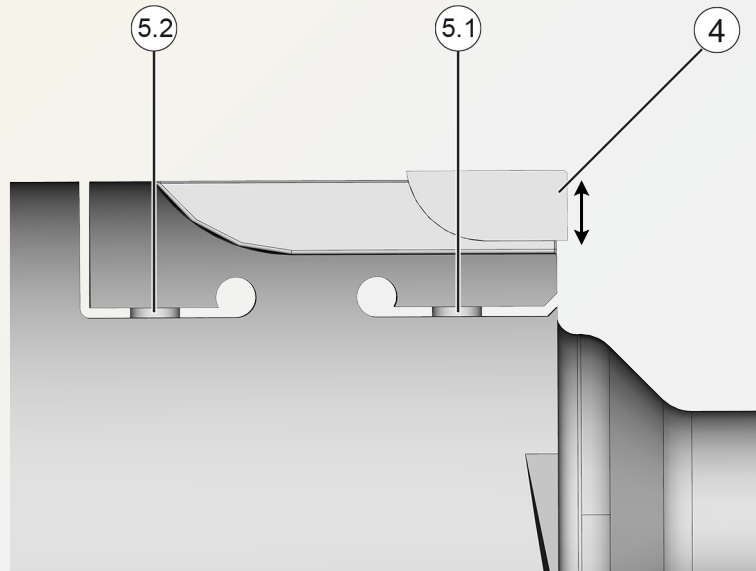

The expansion articulation permits the diameter of the tip (4) that is installed on it to be adjusted such that it is by μm larger or smaller than the nominal size of the tip. Adjustment is performed via the two adjusting spindles (5.1) and (5.2).





5.5 Fine Adjustment of the Expansion Articulation

A fine adjustment of the expansion articulation is necessary when the tool does not reach the required dimension during the initial use in the machine or when it is worn.

NOTE	
 	Risk of damaging the tool Never exceed the maximum torque values that are specified in the Chapter "5.7. Torque Values" when you adjust and lock the expansion adjustment. Disregarding the specifications can damage the tool.

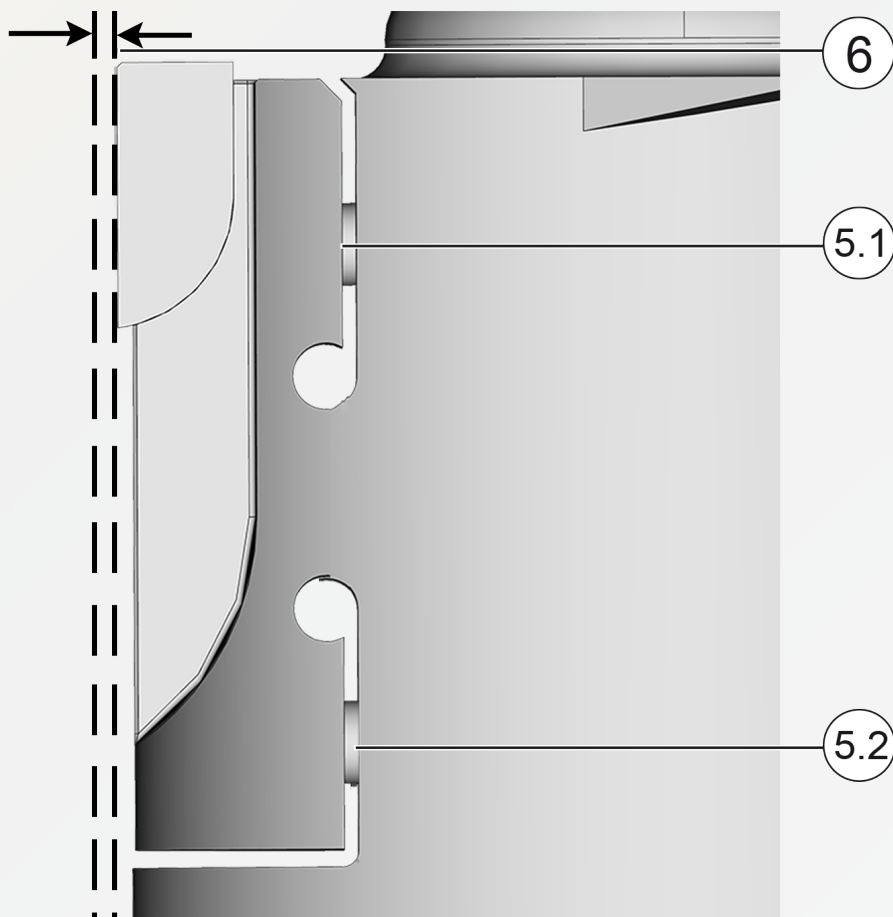

Using the adjusting spindle (5.1), adjust the tip to the required diameter (6). To do this, turn the adjusting screw (3.1) clockwise. Use a torque spanner for this purpose. Observe the torque values specified in Chapter "5.7 Torque Values".

The expansion articulation must be readjusted if you can not reach the required diameter without exceeding the specified torque.



5.6 New Adjustment of the Expansion Articulation

A new adjustment of the expansion articulation is only necessary if you can not carry out the fine adjustment of the expansion articulation inside the specified torque values, or if you want to replace the indexable insert in a tool with indexable insert on the expansion articulation.

NOTE



Risk of damaging the tool

Never exceed the maximum torque values that are specified in the Chapter "5.7. Torque Values" when you adjust and lock the expansion adjustment. Disregarding the specifications can damage the tool.

Use the following procedure to readjust the diameter of the expansion articulation:

1. Turn the two adjusting screws (3.1 and 3.2) anti-clockwise to release the pretension.

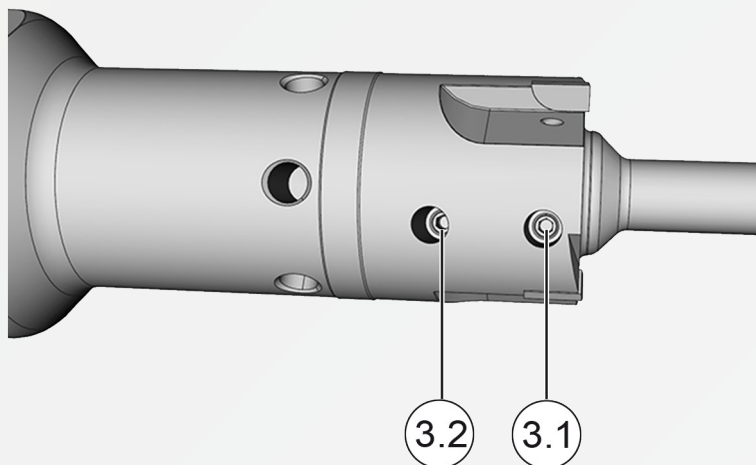



- Using the adjusting spindle (5.1), adjust the tip approximately 10 μm **above** the required diameter (6). To do this, turn the adjusting screw (3.1) clockwise. Use a torque spanner for this purpose. Observe the torque values specified in Chapter "5.7 Torque Values".

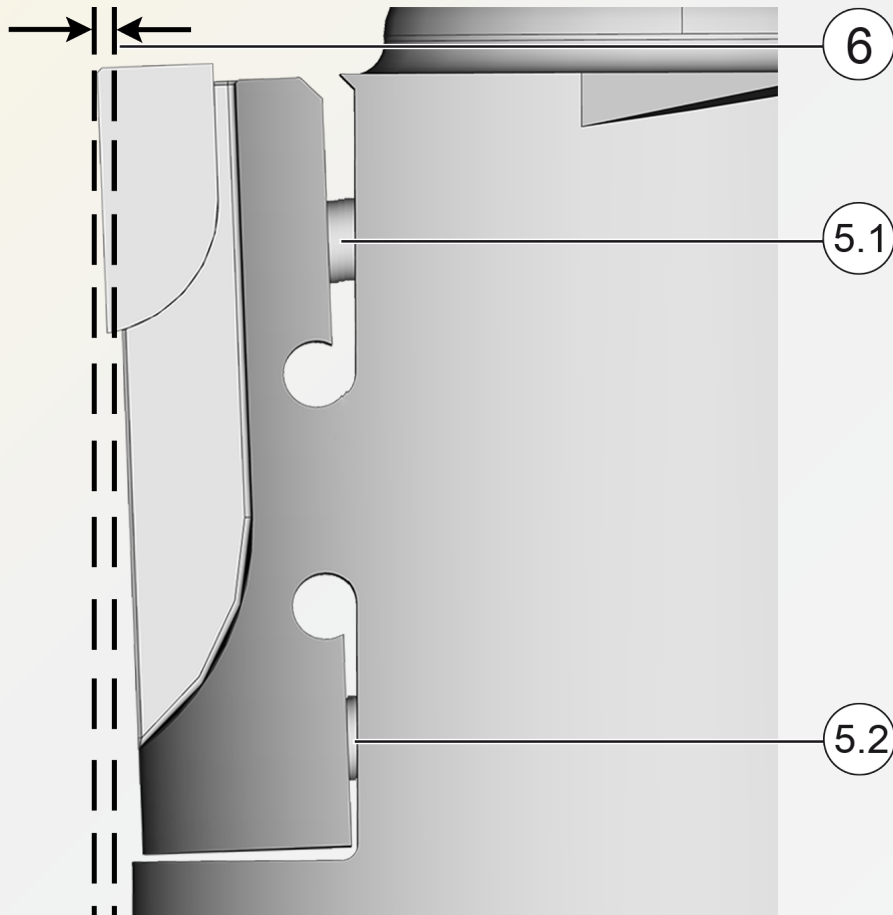



- Using the other adjusting spindle (5.2), set the diameter, which you deliberately set to too large a value, to the correct value. To do this, turn the adjusting screw (3.2) clockwise. This locks the entire system. Use a torque spanner for this purpose. Observe the torque values specified in Chapter "5.7 Torque Values".

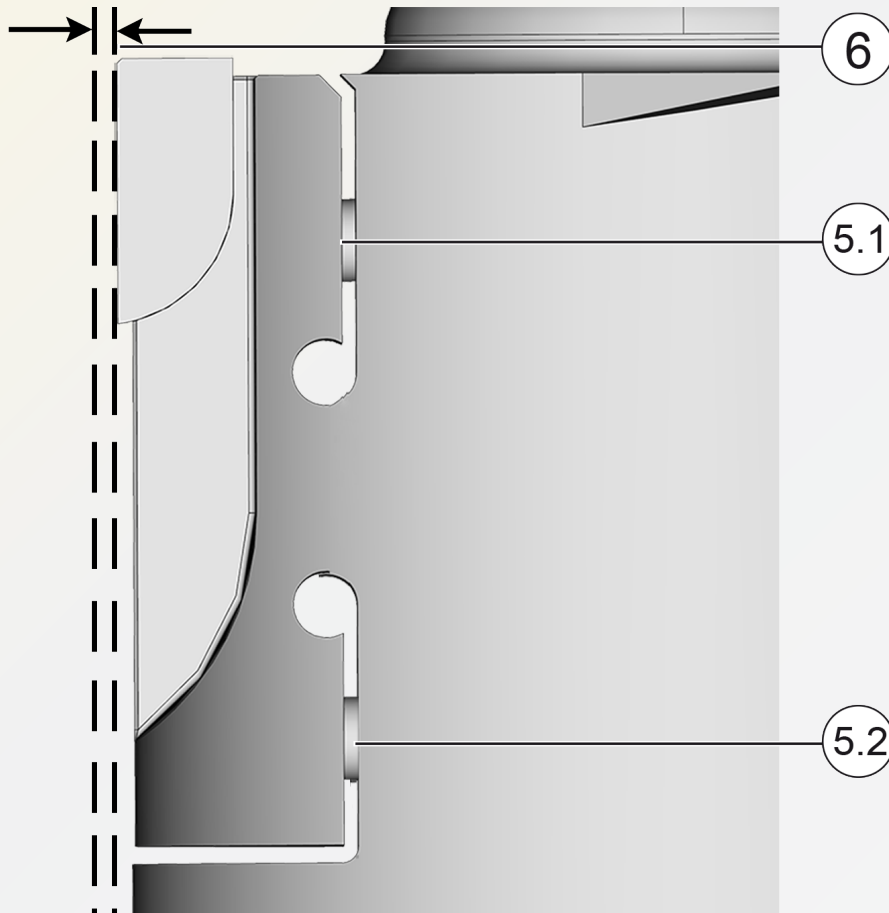

- ✓ The tip in the expansion articulation is set.



5.7 Torque Values

NOTE

**Risk of damaging the tool**

Always ensure that the torque values used for locking the expansion adjustment are not higher or lower than the torque values specified here for the individual nominal sized. Disregarding the specifications can damage the tool.

Ø range [mm]	Min. adjustment range per radius [µm]	Torque [Nm]	Spanner size [mm]
18 ... 24	30	0.4 ... 0.8	2
24 ... 30	50	0.4 ... 0.8	2
30 ... 38	70	0.7 ... 1.5	2.5
38 ... 50	80	2 ... 4	3
≥ 50	150	3 ... 6	4

Proper functioning of the tool can only be ensured when the recommended torque values in this table are observed.